

SCQH VRH/CATTLE CLASSIC

A black silhouette of a cowboy on a horse herding a cow. The cowboy is on the horse, facing right, and the cow is in front of the horse, also facing right. The entire scene is set against a white background.

February 9-12, 2023

Pattern Book

*****RANCH TRAIL PATTERNS WILL BE AVAILABLE ON FRIDAY*****

Thursday 2/9/23

All Working Cow Horse & Boxing

WORKING COW HORSE PATTERN 9

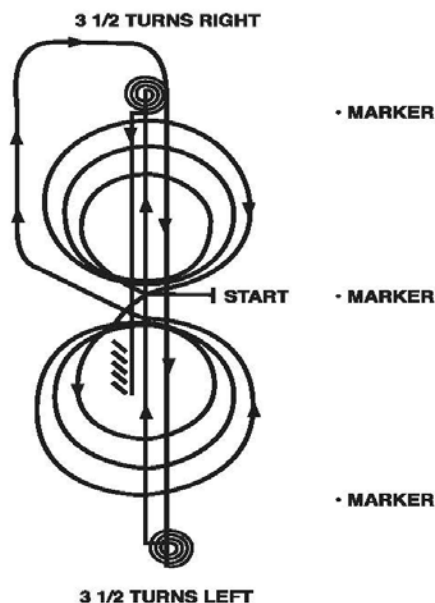

Trot to center of arena, stop. Start pattern facing toward judge.

1. Beginning on the right lead complete 3 circles to the right; the first circle small and slow followed by two large fast circles. Change leads at the center of the arena.
2. Complete 3 circles to the left, the first circle small and slow followed by two large fast circles. Change leads at the center of the arena.
3. Continue around end of arena without breaking gait or changing leads, run down center of arena past end marker, and execute a square sliding stop.
4. Complete 3 1/2 spins to the left.
5. Run down center of arena past end marker, and execute a square sliding stop.
6. Complete 3 1/2 spins to the right.
7. Run down center of arena past center marker, and execute a square sliding stop. Back up at least 10 feet. Hesitate to complete pattern.

PATTERN 9

- | | |
|---------------------|----------------------|
| 1. Right circles | 5. Stop |
| 2. Left circles | 6. 3 1/2 right spins |
| 3. Stop | 7. Stop and back up |
| 4. 3 1/2 left spins | |

This pattern may be used as a lope-in pattern; refer to SHW505.2.

Thursday 2/9/23

All VRH Ranch Reining & RHC Working Ranch Horse

VRH AND RHC Ranch Reining Pattern 1

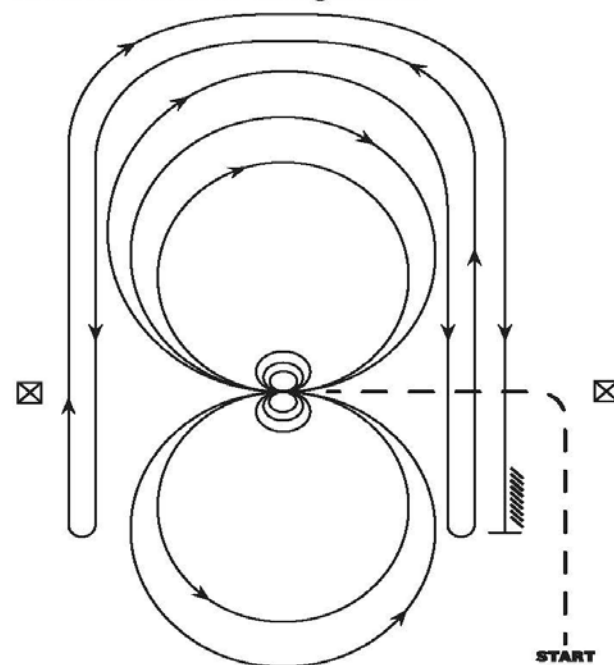

Mandatory Markers along Fence or Wall: The judge shall indicate with markers on arena fence or wall the center of the pattern.

Ride pattern as follows: Trot to center of arena and stop.

1. Complete 3 spins in one direction. Hesitate.
2. Complete 3 spins in the opposite direction. Hesitate.
3. Beginning on right lead, complete two large fast circles to the right. Change leads at center of arena.
4. Complete two large fast circles to the left. Change leads at center of arena.
5. Begin a large circle to the right but do not close this circle. Run down the right side of the arena past the center marker and do a left roll back at least 20 feet from the wall or fence, no hesitation.
6. Continue back around the previous circle but do not close this circle. Run down the left side of the arena past the center marker and do a right roll back at least 20 feet from the wall or fence, no hesitation.
7. Continue back around previous circle, but do not close this circle. Run down the right side of the arena past the center marker and do a sliding stop at least 20 feet from the wall or fence. Back up at least 10 feet. Hesitate to show completion of pattern.

Thursday 2/9/23

All AQHA Reining

REINING PATTERN 6

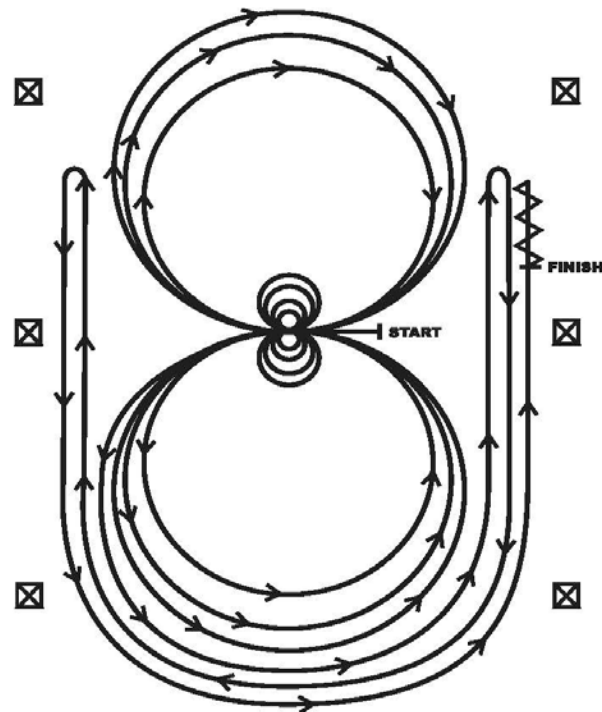

Horses may walk or jog to the center of arena. Horses must walk or stop prior to starting pattern. Beginning at the center of the arena facing the left wall or fence.

1. Complete four spins to the right. Hesitate.
2. Complete four spins to the left. Hesitate.
3. Beginning on the left lead, complete three circles to the left: the first two circles large and fast; the third circle small and slow. Change leads at the center of the arena.
4. Complete three circles to the right: the first two circles large and fast; the third circle small and slow. Change leads at the center of the arena.
5. Begin a large circle to the left but do not close this circle. Run up the right side of the arena past the center marker and do a right rollback at least twenty feet (six meters) from the wall or fence—no hesitation.
6. Continue back around previous circle but do not close this circle. Run up the left side of the arena past the center marker and do a left rollback at least twenty feet (six meters) from the wall or fence—no hesitation.
7. Continue back around previous circle but do not close this circle. Run up the right side of the arena past the center marker and do a sliding stop at least twenty feet (six meters) from the wall or fence. Back up at least ten feet (three meters). Hesitate to demonstrate the completion of the pattern.

Friday 2/10/23

All AQHA Working Cow Horse & Boxing

WORKING COW HORSE PATTERN 12

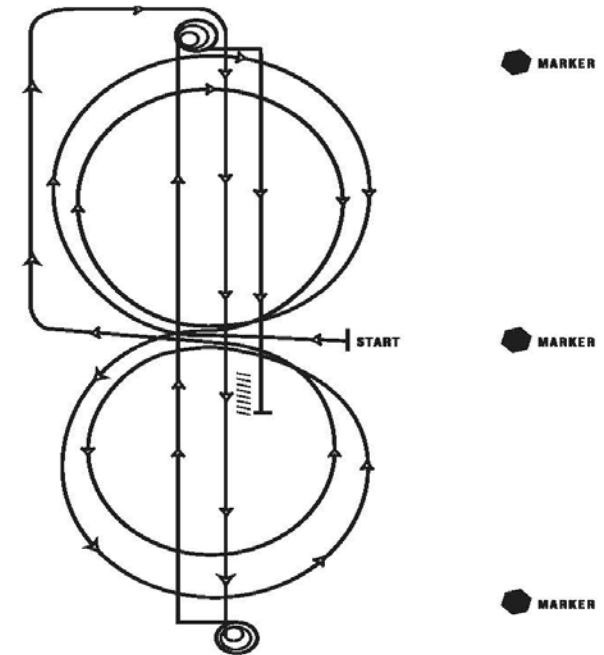

Trot to center of arena, stop. Start pattern facing toward judge.

1. Beginning on the right lead complete 2 circles to the right; the first circle large and fast and the second small and slow. Change leads at the center of the arena.
2. Complete 2 circles to the left, the first circle large and fast and the second small and slow. Change leads at the center of the arena.
3. Continue around end of arena without breaking gait or changing leads, run down center of arena past end marker, and execute a square sliding stop.
4. Complete 3 1/2 spins to the left.
5. Run down center of arena past end marker, and execute a square sliding stop.
6. Complete 3 1/2 spins to the right.
7. Run down center of arena past center marker, and execute a square sliding stop. Back up at least 10 feet. Hesitate.

PATTERN 12

- | | |
|---------------------|----------------------|
| 1. Right circles | 5. Stop |
| 2. Left circles | 6. 3 1/2 right spins |
| 3. Stop | 7. Stop and back up |
| 4. 3 1/2 left spins | |

This pattern may be used as a lope-in pattern; refer to SHW505.2.

RANCH RIDING - PATTERN 12

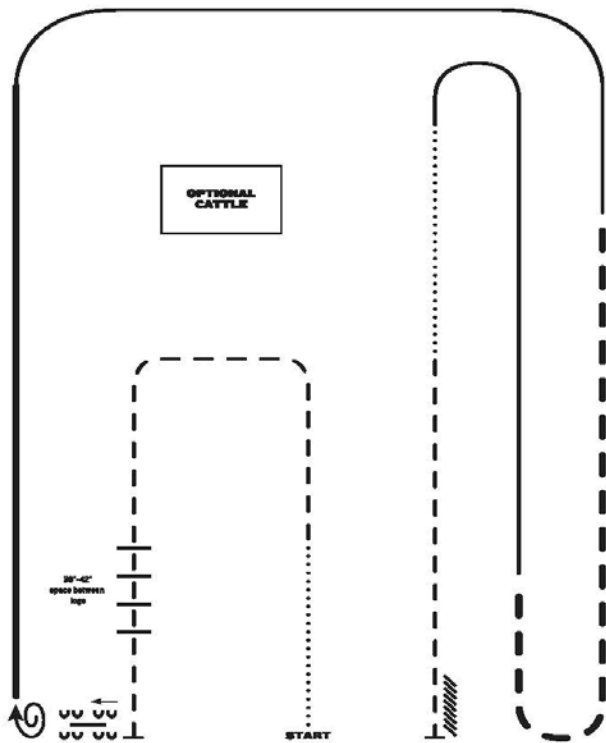

LEGEND

- Walk
- Extended Walk
- - - Trot
- - - Extended Trot
- Lope
- Extended Lope
- ////// Back
- W Lead Change

1. Walk
2. Trot
3. Trot over logs, stop
4. Side pass right over log
5. 1 1/2 turn right
6. Extended lope right lead
7. Lope right lead
8. Extended trot
9. Lope left lead
10. Walk
11. Trot
12. Stop and back

Note: The drawn description of this pattern is only intended for the general depiction of the pattern. Exhibitors should utilize the arena space to best exhibit their horses.

VRH AND RHC Ranch Reining Pattern 6

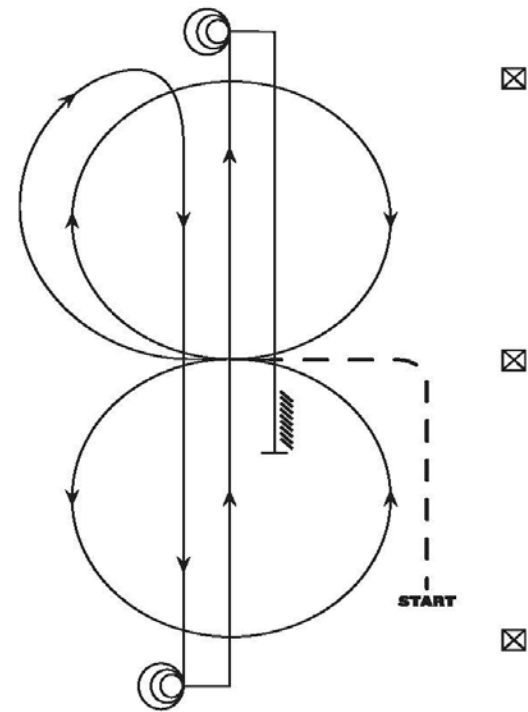

Mandatory Marker along Fence or Wall: The judge shall indicate with markers on arena wall or fence the center of pattern. Judge shall also place markers on fence or wall at least 50' from each end of the arena.

Ride pattern as follows: Trot to center of arena and stop or walk before departure. Start pattern facing toward judge.

1. Beginning on right lead, lope one circle to the right. Change leads at center of arena.
2. Complete one circle to the left. Change leads at center of arena.
3. Begin a circle to the right, but do not close this circle. Run down center of arena, past the end marker, and do a sliding stop.
4. Complete 3 1/2 spins to the right.
5. Run up to other end of arena, past the end marker, do a sliding stop.
6. Complete 3 1/2 spins to the left.
7. Run past the center marker and do a sliding stop. Back at least 10 feet. Hesitate to show completion pattern.

Friday 2/10/23

All AQHA Reining

REINING PATTERN 11

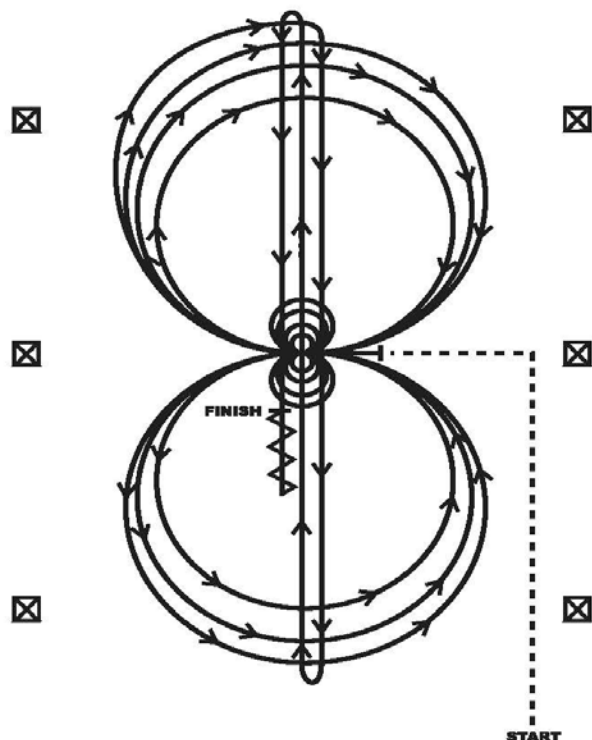

Horses must jog to the center of the arena. Horses must walk or stop prior to starting the pattern. Beginning at the center of the arena facing the left wall or fence.

1. Complete four spins to the left. Hesitate.
2. Complete four spins to the right. Hesitate.
3. Beginning on the right lead complete three circles to the right; the first circle small and slow; the next two circles large and fast. Change leads at the center of the arena.
4. Complete three circles to the left; the first circle small and slow; the next two circles large and fast. Change leads at the center of the arena.
5. Begin a large circle to the right, but do not close this circle. Run down the center of the arena past the end marker and do a right rollback—no hesitation.
6. Run up the middle to the opposite end of the arena past the end marker and do a left rollback—no hesitation.
7. Run past the center marker and do a sliding stop. Back up to the center of the arena or at least ten feet (three meters). Hesitate to demonstrate completion of the pattern.

Saturday 2/11/23

All AQHA & VRH Ranch Riding

RANCH RIDING - PATTERN 6

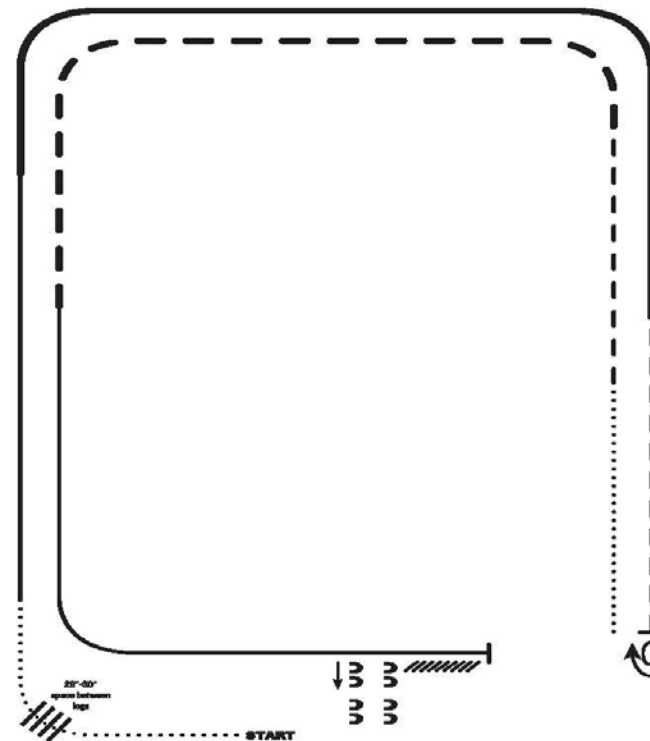

1. Walk
2. Walk over logs
3. Lope right lead
4. Extended lope right lead
5. Trot
6. Stop, 1 1/2 turn right
7. Walk
8. Trot
9. Extended trot
10. Lope left lead
11. Stop and back
12. Side pass right

LEGEND

.....	Walk
- - - - -	Extended Walk
- - - - -	Trot
- - - - -	Extended Trot
- - - - -	Lope
- - - - -	Extended Lope
///////	Back
W	Lead Change

Note: The drawn description of this pattern is only intended for the general depiction of the pattern. Exhibitors should utilize the arena space to best exhibit their horses.

Saturday 2/11/23
L1 Youth & Youth Showmanship

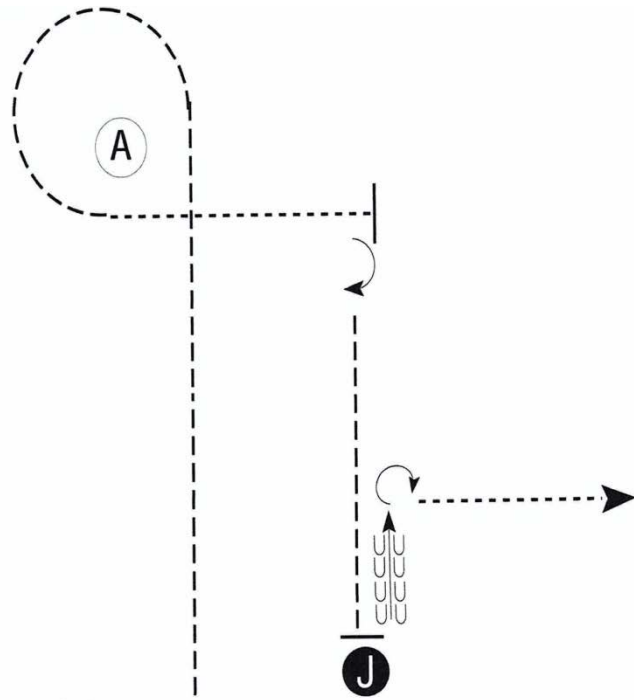

Be ready even with judge.

1. Trot to and around A.
2. Walk from A until even with judge.
3. Stop and perform a 90 degree turn.
4. Trot to judge.
5. Stop and set up for inspection.
6. When dismissed, back approximately 2 horse lengths.
7. Perform a 270 degree turn.
8. Walk straight away from judge.

Follow the instructions of your ring steward.

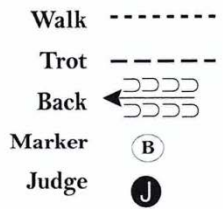

Friday 2/10/23 & Saturday 2/11/23
Small Fry Ranch Riding

Ranch Riding Pattern # 1 Walk Trot SF #1

1. WALK
2. EXTEND TROT 1/2 WAY UP THE ARENA
3. TURN LEFT EXTEND TROT TO CENTER
4. TROT CIRCLE TO THE LEFT
5. STOP
6. 360 degree TURN TO LEFT
7. EXRENDED TROT
8. WALK
9. STOP & BACK ONE HORSE LENGTH

